

HD4MDIH

720P TDN H.264 RUGGED INDOOR/OUTDOOR DOME NETWORK CAMERA

Honeywell's latest addition to the equiP[®] Series of IP-based products, the HD4MDIH is a high definition, True Day/Night rugged indoor/outdoor fixed mini-dome network camera. This ultra compact and vandal-resistant camera provides extremely crisp images at minimal bandwidth. The HD4MDIH provides 720p resolution at full frame rate. Progressive scan technology and 2D edge enhancement provide outstanding clarity and definition. Digital Noise Reduction results in significant storage savings without sacrificing image quality in low light. The 1/4" progressive scan CMOS sensor offers the latest in digital video surveillance technology with accurate color rendition through a wide variety of lighting conditions. The HD4MDIH also supports the PSIA specification for interoperability between network video products.

The HD4MDIH integrates a camera and lens in an ultra compact, single piece, vandal-resistant unit for fast and easy installation in any application. The camera is designed to be surface mounted. Wall and pendant mount kits are also available.

In addition to the low light color performance, the camera will automatically switch to black and white. In this mode, lighting can be complemented with infrared for discreet/covert low light surveillance with exceptional monochrome images.

A 3-D axis gimbal capable of 360° of pan, 180° of tilt and 360° of horizontal rotation simplifies mechanical camera adjustment. The Vari-focal Auto Iris lens allows the field of view to be adjusted to suit the scene requirements and an integrated analog output is provided for the installer to connect a local test monitor while adjusting the scene.

A powerful and intuitive web client allows fine tuning of the camera and the auto iris levels. This can also be performed from most DVR/NVR setup utilities.

The HD4MDIH supports dual video streams and multiple compression formats with rates up to 30 frames per second (25 fps for PAL systems). The digital compression parameters for the two video streams are independently configurable. The primary stream is dedicated to H.264. The secondary stream can be configured for H.264 or MJPEG. A third analog stream can be utilized as backup or for local viewing. It is also valuable when retrofitting onto an existing analog input DVR or encoder (full resolution not available).

With built-in low current Power over Ethernet (IEEE 802.3af), Class 1, power is supplied to the camera using standard network cabling, eliminating the need for a separate power supply and associated wiring. In retrofit situations where PoE switching does not exist, the unit can also be powered directly from 24 V AC.

Market Opportunities

The HD4MDIH is perfect for installations where excellent picture clarity at minimal bandwidth is required. At three times the resolution of standard analog cameras, yet with similar bandwidth requirements, the HD4MDIH can be retrofitted on many existing DVR/NVR installations without requiring additional storage. Its discreet, vandal-resistant, outdoor design provides maximum protection against dust, dirt and water, and provides optimum performance for both indoor and outdoor applications.

Features

- Outstanding image quality, 720p (1280 x 720) resolution
- 30 fps (25 fps PAL) progressive scan
- True Day/Night, VFAI lens with removable IR cut filter
- Camera tamper detection
- Video motion detection
- Wall and pendant mount kit available
- Selectable compression formats
- PSIA support
- Dual digital video streams, independently configurable, H.264 and/or H.264/MJPEG
- Remote firmware update
- Supports both dynamic and static IP addresses
- Includes advanced IP locator software to make system setup easy
- Web server for remote setup of camera video and network parameters
- Choice of 24 V AC or PoE IEEE 802.3af Class 1 power inputs
- Supports input and output alarm contacts
- Supports bidirectional audio
- Rugged polycarbonate dome



HD4MDIH

www.honeywellvideo.com

SPECIFICATIONS

Like all cameras in the equiP IP Series, the HD4MDIH network camera uses Honeywell technology for video motion detection, tamper detection, remote firmware updating and for secure storage of all camera settings. Video motion detection recognizes object motion within the field of view; then a simple on-screen notification alerts the user. Camera tamper detection notifies the user when a camera's field of view is altered, blinded or blurred. This ensures the video's integrity and alerts the customer to either a live event or a system problem that is causing disruption to the video stream. Honeywell's technology also allows users to remotely upload firmware to the camera. Setup is quick and easy and can be customized through a web client or from an NVR or DVR. The built-in web server provides password protected access to the camera's video and network setup.



System Diagram

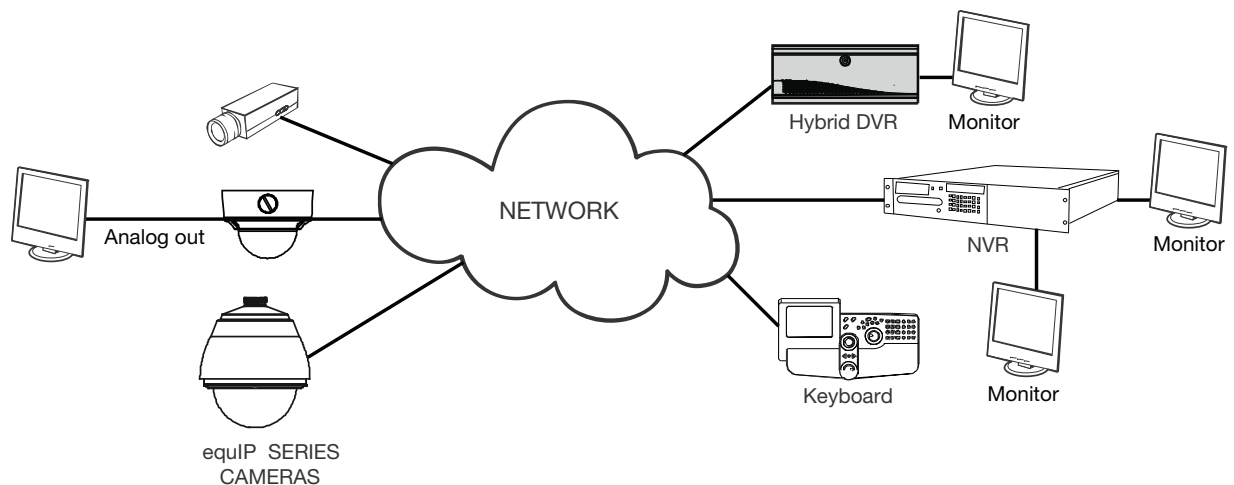

SPECIFICATIONS

Operational	
Video Standard	NTSC, PAL
Scanning System	Progressive scan
Image Sensor	1/4" CMOS
Number of Pixels (H x V)	1280 x 720
Minimum Illumination	0.25 lux color/0.22 lux BW @ 50 IRE, F1.6 0.11 lux color/0.09 lux BW @ 30 IRE, F1.6
Automatic Lens Control	DC Iris Level 1-25
Video Output (AUX)	1.0 Vp-p @ 75 Ohms
S/N Ratio	50 dB or more (AGC off)
Auto Gain Control	Off/On, selectable (10-40 dB)
Automatic Electronic Shutter	1/60-1/24,500 sec (NTSC) 1/50-1/24,500 sec (PAL)
Lens Type	True Day/Night (TDN) 3.3-12 mm Vari-focal Auto Iris, F1.6
White Balance	AWC, AWC Push, Manual
Audio/Two-Way	Line in/out
Electrical	
Input Voltage	24 V AC, PoE IEEE 802.3af, Class 1
Input Range	17-28 V AC
Surge Suppression	1.5 kW transient
Power Consumption	3.5 W (max)
Mechanical	
Dimensions (W x H)	6.1" x 4.6" x (154.94 mm x 117.1 mm)
Weight	3.0 lb (1.3 kg) camera only
Construction	Housing: Die Cast Aluminum Finish: Cool Gray Powder Coat Dome: Polycarbonate
Connector	Video Output (AUX): 2-pin Molex connector Power Input: Removable screw block Network: RJ45 connector Alarm I/O: Removable screw block Audio In: Removable screw block Audio Out: Removable screw block

Environmental			
Temperature	Operating: -22°F to +140°F (-30°C to +60°C) Storage: -40°F to +158°F (-40°C to +70°C)		
Relative Humidity	0% to 85%, non-condensing		
Rating	IP66		
IP Specifications			
Video Compression	Dual stream H.264 and MJPEG		
Resolution	Bitrate H.264 (Typical)*	Frame Rate	Storage/Day (GB)
1280 x 720	1.8 Mbps	30/25	18.98
800 x 450	1.2 Mbps	30/25	12.65
640 x 360	0.6 Mbps	30/25	6.33
320 x 180	0.21 Mbps	30/25	0.89
Frame Rate NTSC/PAL	Up to 30/25 fps video in all resolutions		
Video Streaming	Dual streaming: Controllable frame rate and bandwidth Constant or variable bit rate		
Security	Multiple user access levels with password protection		
Video Access from Web Browser	Full control of all camera settings available to administrator		
Minimum Web Browsing Requirements	Pentium IV CPU 3.1 GHz or faster 1 GB RAM (32-bit) or 2 GB RAM (64-bit) Windows XP® SP3, Windows 2003 Server R2 (32-bit), Windows 7 (32-/64-bit), Windows 2008 Server (32-/64-bit), Windows 2008 R2 (64-bit) Internet Explorer 6,7,8, or 9		
Installation and Management Maintenance	Honeywell IP Utility software identifies the IP address, checks status of device, firmware upgrades over HTTP		
Supported Protocols	HTTP, TCP, RTSP, RTP, UDP, ARP, DNS, RTCP, FTP, ICMP, DHCP, Bonjour, IGMP, Telnet		
Standards	PSIA support		
Regulatory			
Emissions	FCC, CE (EN55022)		
Immunity	CE (EN55024)		
Safety	EU: EN60950-1:2006 North American ETL listed to UL/CSA 60950-1		

*Actual bitrate is scene and motion dependent with H.264 stream.

SPECIFICATIONS

System Integration
Open IP Integration
PSIA support and open API for real interoperability between Honeywell and other manufacturer's IP-enabled security devices. Refer to the Honeywell Open Technology Alliance [http://www.honeywell.com/security/hota] to learn more about our open and integrated solutions.

Recommended Accessories	
Housing Mounts	
HD4CHIP-PK	Pendant Mount Bracket
HD4CHIP-WK	Wall Mount Bracket

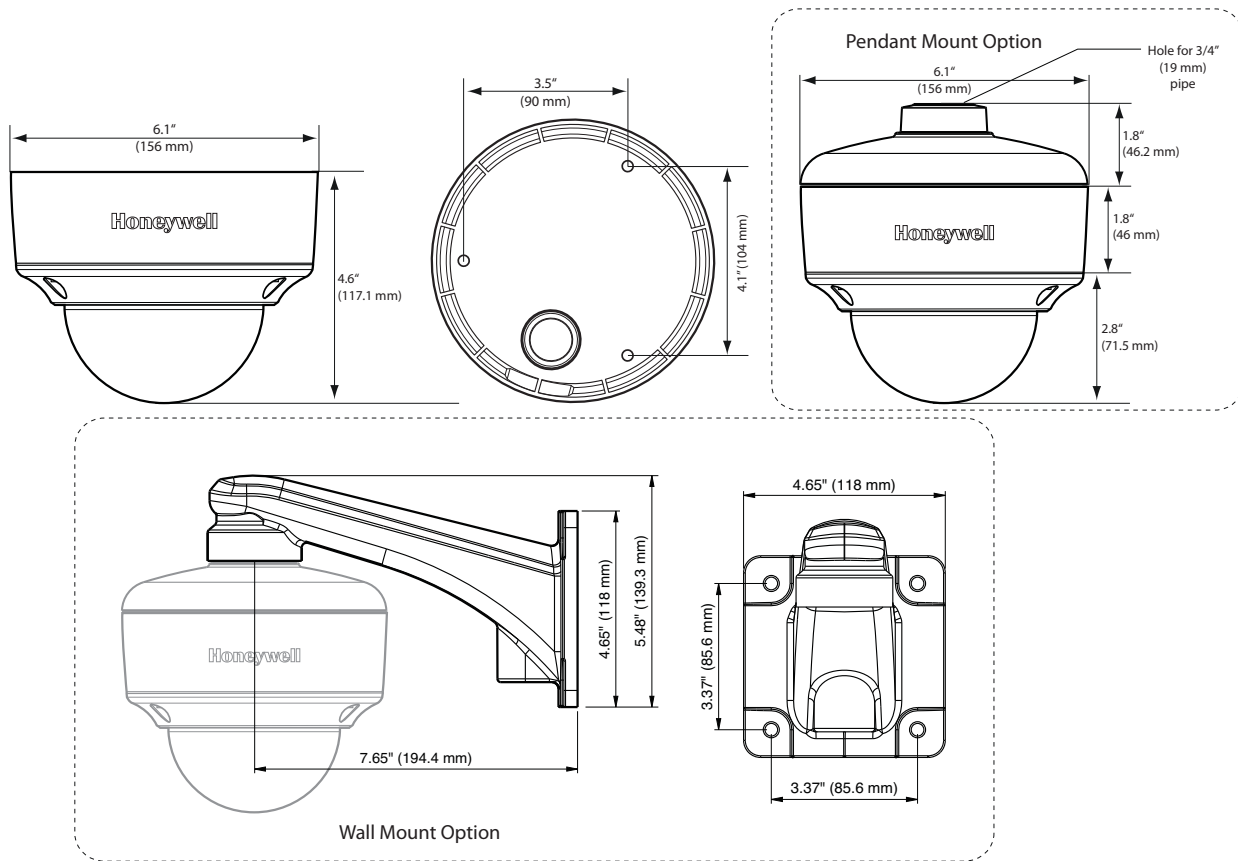

Ordering	
HD4MDIH	Network True Day/Night Rugged Fixed Dome, 1/4" Progressive Scan, CMOS, 720p Resolution Camera, 3.3-12 mm VFAI, 24 V AC or PoE IEEE 802.3af Class 1, H.264, NTSC
HD4MDIHX	Network True Day/Night Rugged Fixed Dome, 1/4" Progressive Scan, CMOS, 720p Resolution Camera, 3.3-12 mm VFAI, 24 V AC or PoE IEEE 802.3af Class 1, H.264, PAL

NOTE: Honeywell reserves the right, without notification, to make changes in product design or specifications.

Automation and Control Solutions

Honeywell Systems
 2700 Blankenbaker Pkwy, Suite 150
 Louisville, KY 40299
 1.800.323.4576
 www.honeywell.com

L/HD4MDIHD/D
 October 2012
 © 2012 Honeywell International Inc.

